



111 Yarrowee Street Sebastopol VIC

3 1 1

This excellent triple front home, is ideally located close to shops, supermarkets, schools and easy access to public transport. Situated on a low maintenance block this home offers, new carpet as well as new block out blinds throughout, giving this stylish home a new update. Featuring three generous bedrooms, one containing a BIR. The spacious kitchen offers plenty of storage, with the inclusion of a dishwasher and gas oven and cooktop, making this a great space for the home cook. Leading through to the open lounge, with large front window to let in lots of natural light. The home is kept comfortable all throughout the year with ceiling fans in each room, ducted heating, as well as, split systems in both the master bedroom and kitchen/dining. The back of the home features a sunroom and separate laundry. Outside there is side gate access to the large single c ...

Price : \$ 395,000

View : <https://www.ballaratrealestate.com.au/sale/vic/ballarat-western-district/sebastopol/residential/house/7263587>



Alex Stepnell
03 53312233
0407373507

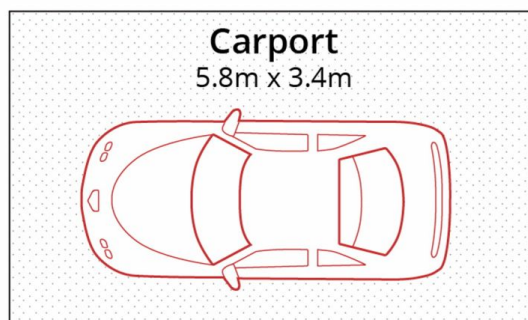
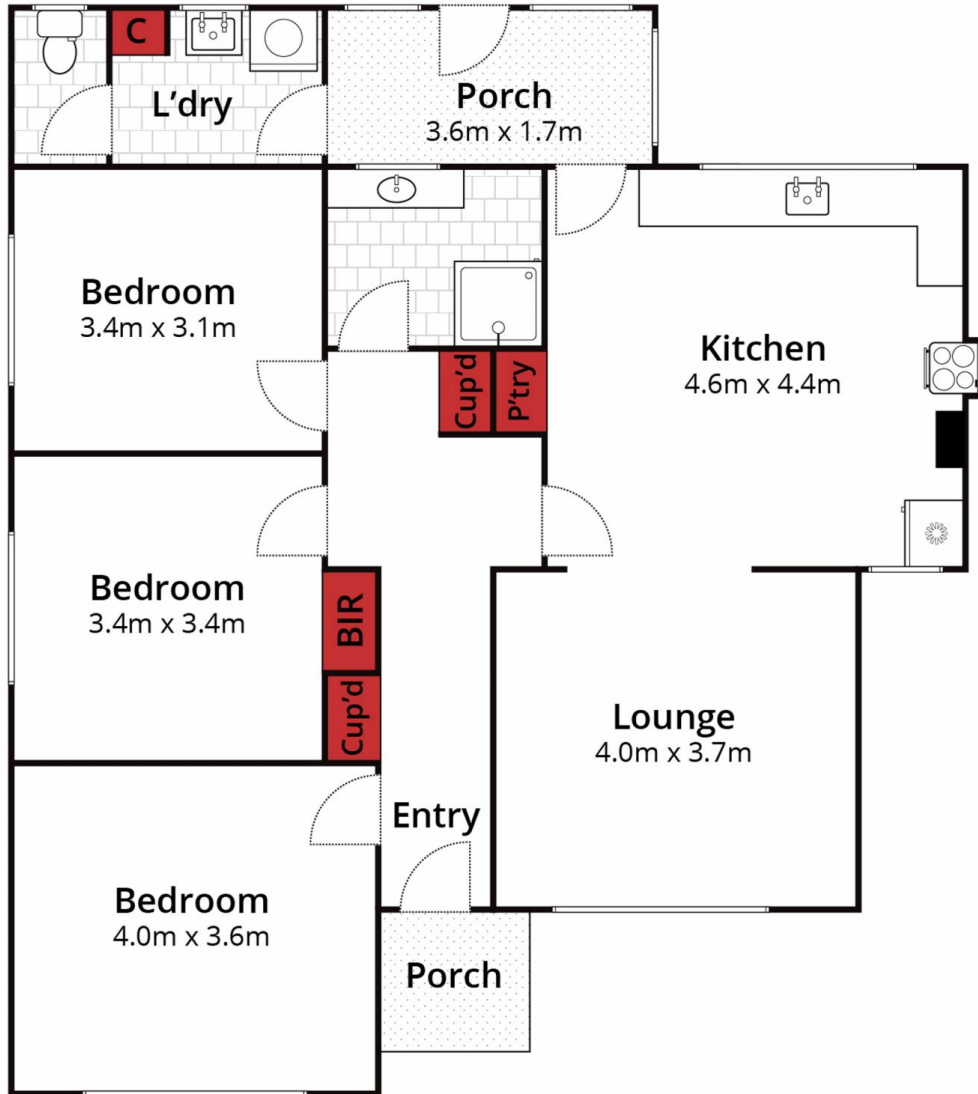

(Not In Position)



Whilst bwrn.com.au has made every attempt to ensure the accuracy of the floor plan contained here, measurements are approximate and no responsibility is taken for any error, omission, or mis-statement. This plan is for illustrative purposes only.

111 Yarrowee Street, Sebastopol

