



1/719 Geelong Road Canadian VIC

3 1 1

Conveniently located within walking distance from Sovereign Hill, Golden Point Hotel and public transport is this great opportunity for the astute investor, first home buyer or astute Air BNB Super host.

The home consists of three bedrooms, a centrally located bathroom with second separate toilet, a light filled open plan kitchen and meals area. The family room with split system opens out onto a private decked area. With gas central heating, you will be in comfort year-round. The property also boasts a single carport and spacious front yard. Currently operating as a thriving Airbnb business and has a proven track record with a return of approximately \$50,000 per annum. Contact Damian Larkin on 0417 088 755 to book your private viewing.

Price : \$ 450,000
Land Size : 402 sqm
View : <https://www.ballaratrealestate.com.au/sale/vic/ballarat-western-district/canadian/residential/house/7514691>

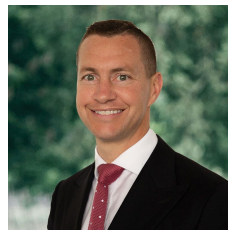

Damian Larkin
03 53312233
0417 088 755

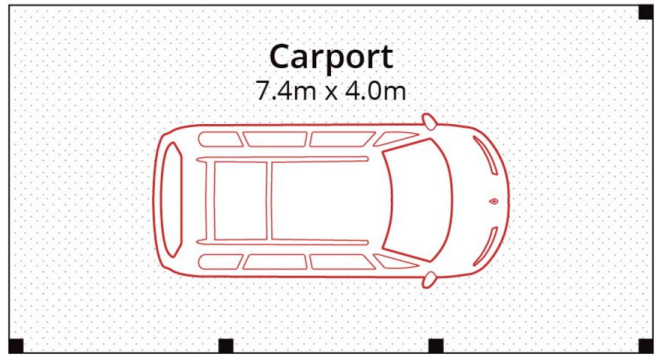

(Not In Position)

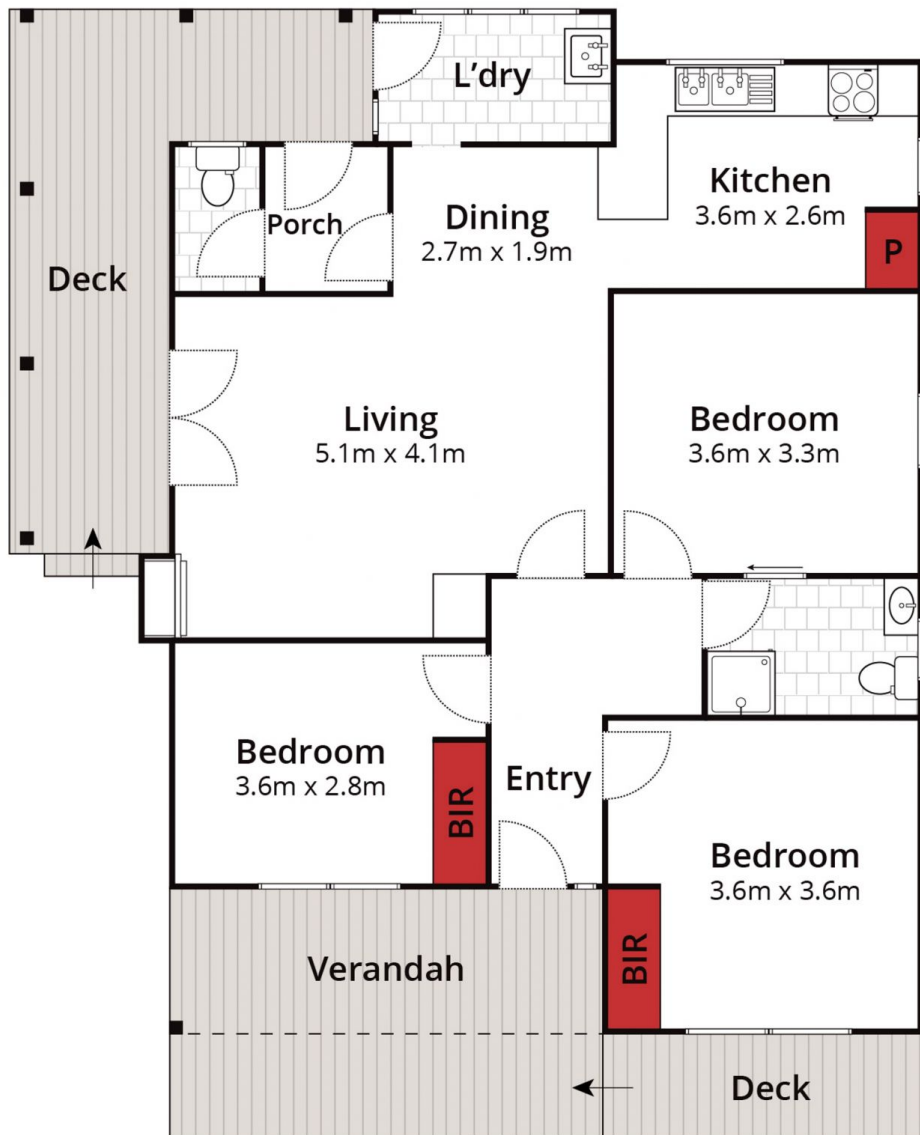

Approx House Area 87m²
Approx Land Area 402m²



Whilst bwrn.com.au has made every attempt to ensure the accuracy of the floor plan contained here, measurements are approximate and no responsibility is taken for any error, omission, or mis-statement. This plan is for illustrative purposes only.

1/719 Geelong Road, Canadian

Ballarat
Real Estate

